

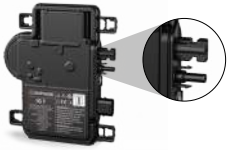

# IQ7 Series Microinverters

The high-powered smart grid-ready Enphase IQ7 Series Microinverters dramatically simplify the installation process while achieving the highest system performance.



IQ7 Series with integrated MC4 connectors

Connect PV modules quickly and easily to the IQ7 Series Microinverters that has integrated MC4 connectors.



IQ Gateway

The IQ Gateway is the platform for energy management and integrates with the IQ Microinverters and IQ Batteries to provide complete control and insights into the Enphase Energy System.



IQ Cables

The IQ Cables allow quick and safe connection of the microinverters. With 3P variants, the installed capacity is automatically distributed evenly across all three phases.



IQ Relay single-phase and multi-phase

Production and storage, circuit integrated, NS-protection device with PLC-Phase coupler (3P) and DC current injection monitoring\*.

## Easy to install

- Lightweight and compact with plug-and-play connectors
- Power line communication (PLC) between components
- Familiar AC cabling architecture

## High productivity and reliability

- More than one million cumulative hours of testing
- Class II double-insulated enclosure
- Safer AC cabling methods

## Smart grid-ready

- Complies with the latest advanced grid support
- Remote automatic updates for the latest grid requirements
- Configurable to support a wide range of grid profiles



IQ7 Series Microinverters redefine reliability standards with more than one million cumulative hours of power-on testing, enabling an industry-leading limited warranty of up to 25 years\*\*.

\* IQ Relay is not required in all countries, check local grid connection requirements to confirm.

\*\* 25 years warranty is valid, provided an internet-connected IQ Gateway is installed.

# IQ7 Series Microinverters

INPUT DATA (DC)		UNITS	IQ7-60-M-INT	IQ7PLUS-72-M-INT	IQ7A-72-M-INT
Typical module compatibility			60-cell/120-half-cell	60-cell/120-half-cell 66-cell/132-half-cell 72-cell/144-half-cell	60-cell/120-half-cell 66-cell/132-half-cell 72-cell/144-half-cell
			No enforced DC/AC ratio and maximum input power. Modules can be paired as long as the maximum input voltage is not exceeded and the maximum input current of the inverter at the lowest and highest temperatures is respected. See the compatibility calculator at <a href="https://enphase.com/installers/microinverters/calculator">https://enphase.com/installers/microinverters/calculator</a> .		
Minimum/Maximum input voltage	$U_{dcmin} / U_{dcmax}$	V	16/48	16/60	18/58
Start-up input voltage	$U_{dcstart}$	V	22	22	33
Rated input voltage	$U_{dc,r}$	V	32	36	40.5
Minimum/Maximum MPP voltage	$U_{mppmin} / U_{mppmax}$	V	27/37	27/45	38/43
Minimum/Maximum operating voltage	$U_{opmin} / U_{opmax}$	V	16/48	16/60	18/58
Maximum input current	$I_{dcmax}$	A	10	12	10.2
Maximum short-circuit DC input current	$I_{scmax}$	A	25	25	25
Maximum module Isc		A	20	20	20
Maximum input power	$P_{dcmax}$	W	350	440	500
OUTPUT DATA (AC)		UNITS	IQ7-60-M-INT	IQ7PLUS-72-M-INT	IQ7A-72-M-INT
Maximum apparent power	$S_{ac,max}$	VA	245	295	366
Rated power	$P_{ac,r}$	W	240	290	349
Nominal grid voltage	$U_{acnom}$	V		230	
Minimum/Maximum grid voltage	$U_{acmin} / U_{acmax}$	V		184/276	
Maximum output current	$I_{acmax}$	A	1.07	1.28	1.59
Nominal frequency	$f_{nom}$	Hz		50	
Minimum/Maximum frequency	$f_{min} / f_{max}$	Hz		45/55	
Maximum units per single-phase/multi-phase 20 A circuit		A	15 (L+N)/45 (3L+N)	12 (L+N)/36 (3L+N)	10 (L+N)/30 (3L+N)
			For IQ Cable with 2.5 mm <sup>2</sup> stranded conductors and using a 1.25 safety factor, 16 A per phase is calculated as the maximum current according to IEC 60364. The safety factors applied may vary based on local regulations or best practices, also upon the characteristic the OCPD selected.		
Maximum units per single-phase/multi-phase IQ Cable section			15 (L+N)/24 (3L+N)	12 (L+N)/21 (3L+N)	10 (L+N)/18 (3L+N)
			Centre feeding is the best practice. These design limits should ensure voltage rise and line conductor resistance on the IQ Cable are maintained within the acceptable limits. In locations with risk of high grid voltage at the point of connection, it may be necessary to decrease the maximum number of microinverters on the IQ Cable section by as much as 50%.		
Protective class (all ports)				II	
Total harmonic distortion		%		<5	
Power factor setting				1.0	
Power factor range	cos phi			0.8 leading ... 0.8 lagging	
Inverter maximum efficiency	$\eta_{max}$	%	97.40	97.24	97.23
European weighted efficiency	$\eta_{EU}$	%		96.50	
Inverter topology				Isolated (HF Transformer)	
Nighttime power loss		mW		50	
MECHANICAL DATA			IQ7-60-M-INT	IQ7PLUS-72-M-INT	IQ7A-72-M-INT
Ambient air temperature range			-40°C to 65 °C (-40°F to 149°F)		-40°C to 60 °C (-40°F to 140°F)
Relative humidity range			4% to 100% (condensing)		
Overvoltage class AC port			III		
Number of input DC connectors (pairs) per single MPP-tracker			1		
AC Connector type			Enphase IQ Cabling (refer to separate datasheet for cable and accessories)		

MECHANICAL DATA	IQ7-60-M-INT	IQ7PLUS-72-M-INT	IQ7A-72-M-INT
DC connector type	Stäubli made MC4		
Dimensions (H×W×D)	212 mm (8.3") × 175 mm (6.9") × 30.2 mm (1.2") (without mounting brackets)		
Weight (with mounting plate)	1.1 kg (2.4 lbs)		
Cooling	Natural convection – no fans		
Enclosure	Class II double-insulated, corrosion-resistant polymeric enclosure		
IP Rating	Outdoor - IP67		
Maximum altitude	<2600 m		
Calorific value	37.5 MJ/unit		
STANDARDS	IQ7-60-M-INT	IQ7PLUS-72-M-INT	IQ7A-72-M-INT
Grid-Compliance (with IQ Relay)	TOR Erzeuger Typ A, C10/11, PPDS Annex 4, VFR 2019, VDE-AR-N 4105:2018, CEI 0-21, NEN1010, EN 50549-1, UNE206007-1/2		
Grid-Compliance (without IQ Relay)	G98, G98 NI, G99, G99 NI, G100		
Safety	EN IEC 62109-1, EN IEC 62109-2		
EMC	EN IEC 61000-3-2, 61000-3-3, 61000-6-2, 61000-6-3, EN IEC 50065-1, 50065-2-1		
Product labelling	CE, UKCA, and RCM		
Advanced grid functions <sup>1</sup>	Power export limiting (PEL), phase imbalance management (PIM), loss of phase detection (LOP), power factor control Q (U), cos (phi) (P)		
Microinverter communication	Power line communication (PLC) 110–120 kHz (Class B), Narrowband 200 Hz		

(1) Some of these functions require IQ Gateway Metered with current transformers and/or IQ Relay installed.

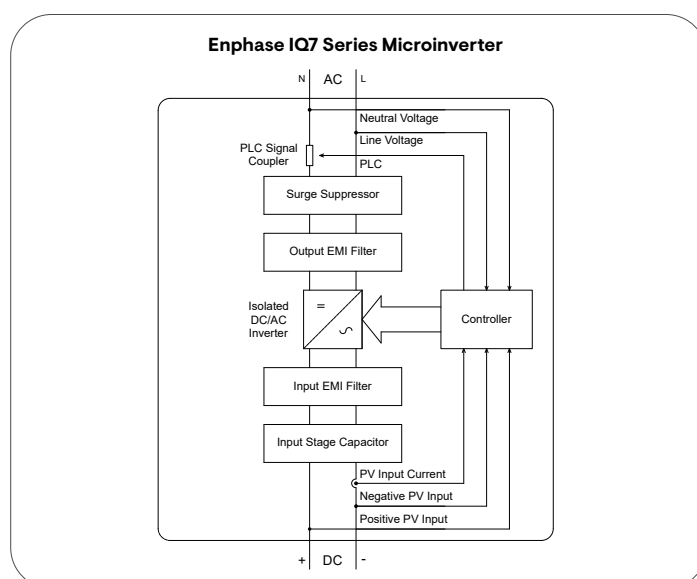
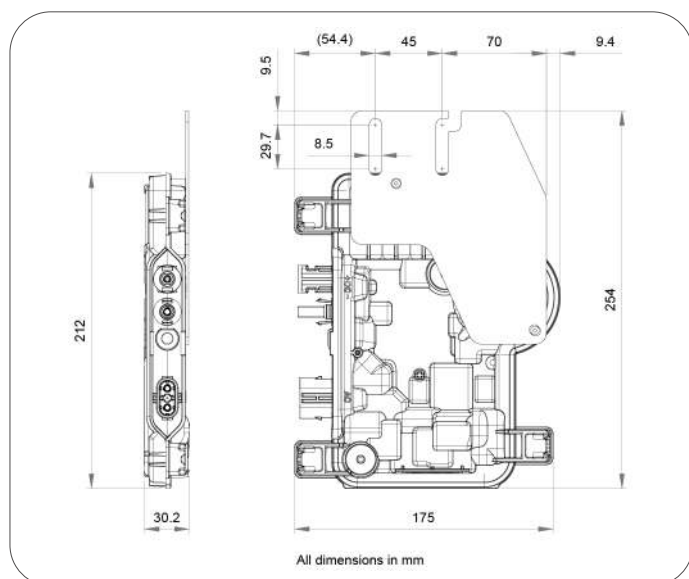
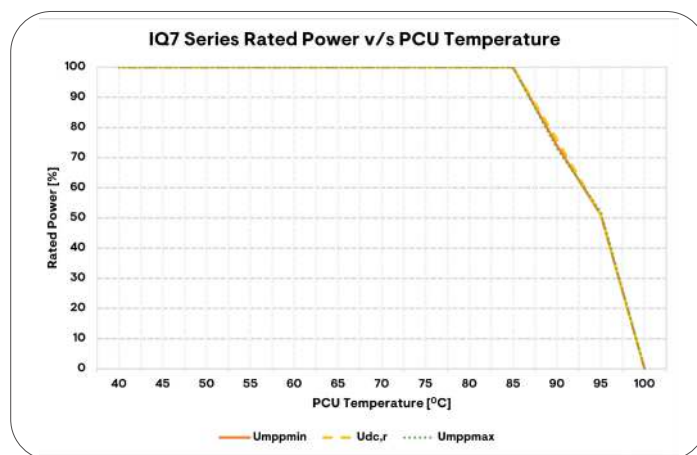
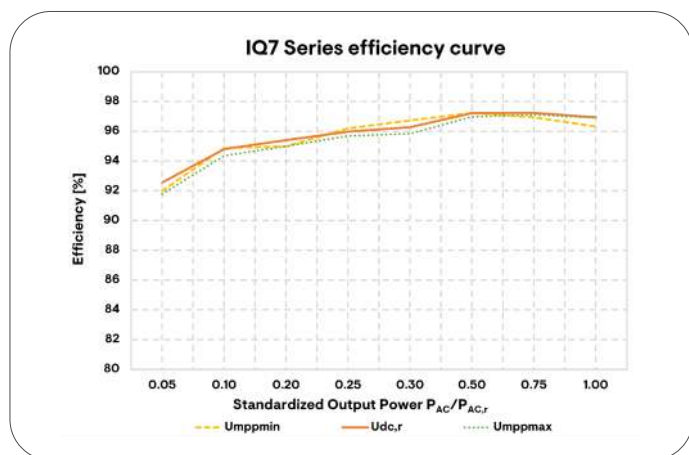

Assembled in China, India, and Mexico.

Enphase Energy NL B.V. Het Zuiderkruis 65 5215 MV, s-Hertogenbosch, The Netherlands Tel: +31 73 303 64 50

IQ7-MC4-DSH-00024-1.0-EN-EU-05-10-2023

# Revision history

REVISION	DATE	DESCRIPTION
DSH-00024-1.0	May 2023	Updated the datasheet as per EN 50524:2021 compliance
Previous releases		